

# Hercular™ -dead bolt

## Installation instruction

**1**

Position installation template at proper height on the door. Mark center for 2 1/8" (54 mm) diameter hole at correct backset. Mark center of door thickness for bolt hole.

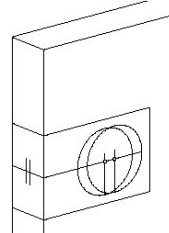

1

**2**

Drill a 2 1/8" (54 mm) through hole on door side. Drill a 1" (25 mm) hole for front plate bolt or a 1 1/8" (28 mm) for a drive in bolt, to a depth of 3 3/4" (95 mm). Recess for bolt face if necessary.

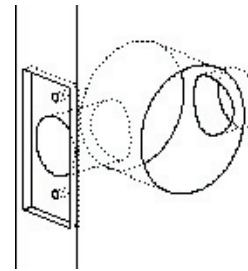

2

**3**

Strike type-Install bolt as shown in diagram. Fasten with screws.

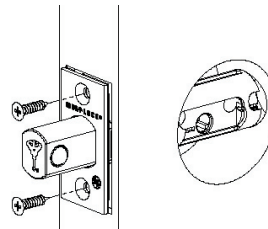

3

**4**

Drive in type-install bolt as shown in diagram. Tap into place with hammer until flush with door.

**Note! Don't throb on bolt use a piece of wood as a buffer.**

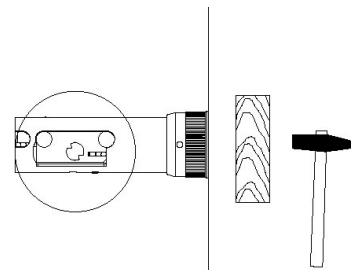

4



An Assa Abloy Group company

**Mul-T-Lock Technologies Ltd**  
P.O.B. 637, Yavne 81104 Israel [www.multlock.com](http://www.multlock.com)

The MUL-T-LOCK® name and the muscleman logo are registered trademark of MUL-T-LOCK LTD.  
MUL-T-LOCK reserved the right to make any product improvements or modifications without prior notice.

D.c

# Hercular™ -dead bolt

## Installation instruction

5

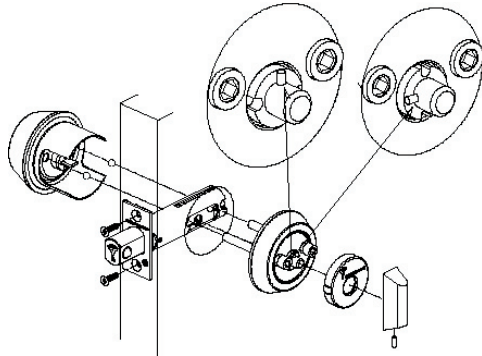

6

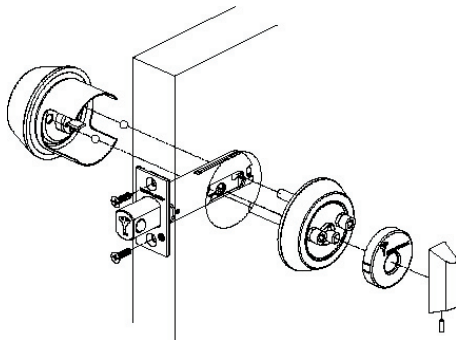

7

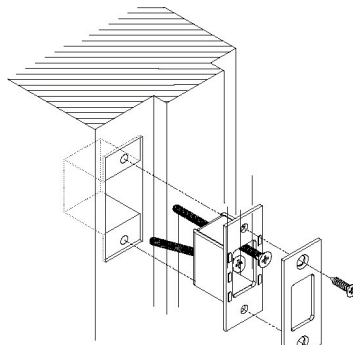

**5**

Tumbturn type Shorten the tail piece on cylinder side according to door thickness.

Remove thumbturn and cover plate on thumbturn side.

Place steel balls inside mounting screws holes.

Insert exterior cylinder

Insert cylinder thumbturn unit into position in a vertical or horizontal position (according to customer requirements).

Tighten mounting screws.

Check operation.

Install cover plate and tumbturn.

**6**

Double cylinder Shorten the tail piece on both side according to door thickness.

Remove cover plate on inner side.

Place steel balls inside mounting screws holes.

Insert cylinders into position.

Tighten mounting screws.

Check operation.

Install cover plate back in place.

**7**

Mark frame opposite to center of bolt.

Drill and recess as necessary for strike plate and box.

Drill  $\frac{1}{8}$  (3 mm) pilot holes for long screws

Install box and strike as shown in diagram



**MUL-T-LOCK®**

An Assa Abloy Group company

Mul-T-Lock Technologies Ltd  
P.O.B. 637, Yavne 81104 Israel [www.multlock.com](http://www.multlock.com)

The MUL-T-LOCK® name and the muscleman logo are registered trademark of MUL-T-LOCK LTD.  
MUL-T-LOCK reserved the right to make any product improvements or modifications without prior notice.

**D.d**

# Hercular™ -dead bolt

## Changing backset

**1**

Hold the bolt in lock position.  
Press pin (\*) into the bolt housing.

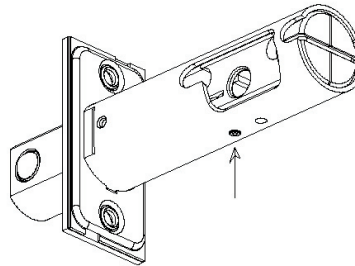

1

**2**

Take out the mechanism through the bolt housing.

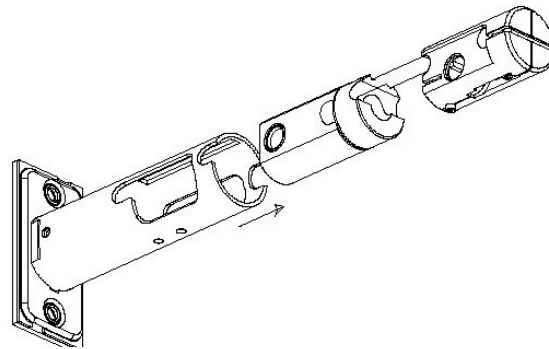

2

**3**

Change arm position into the other socket at the edge of the bolt.

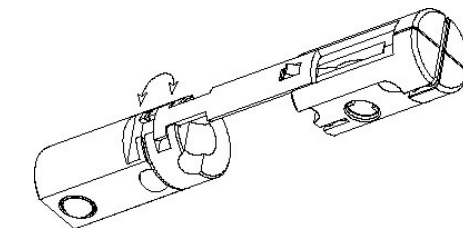

3

**4**

Insert the mechanism back into the housing till the pin pops out from the first bore

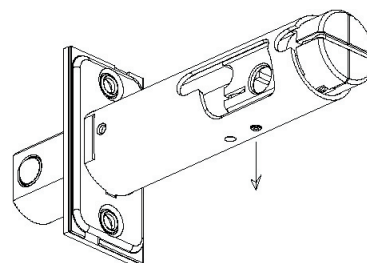

4



An Assa Abloy Group company

Mul-T-Lock Technologies Ltd  
P.O.B. 637, Yavne 81104 Israel [www.multlock.com](http://www.multlock.com)

The MUL-T-LOCK® name and the muscleman logo are registered trademark of MUL-T-LOCK LTD.  
MUL-T-LOCK reserved the right to make any product improvements or modifications without prior notice.

D.b

### ***Step 1***

- Hold the bolt in the locked position (Bolt extended)..
- Press the pin into the bolt housing.

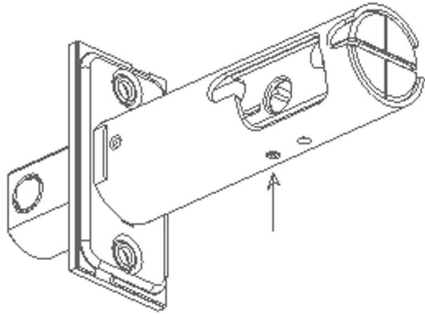

### ***Step 2***

- Remove the mechanism from the bolt housing.

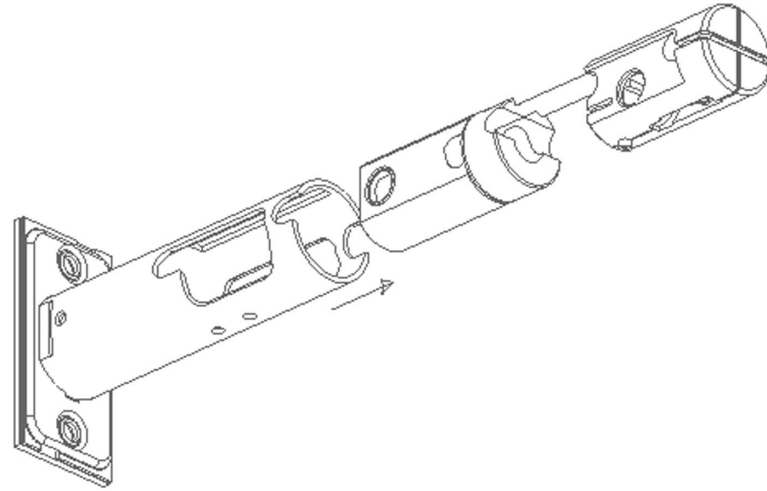

### ***Step 3***

- Remove the arm into the other socket at the edge of the bolt.

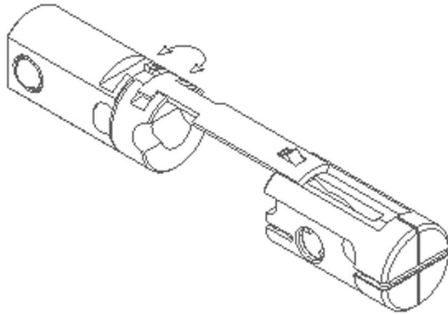

### ***Step 4***

- Insert the mechanism back into the housing until the pin pops out from the first hole.

